



ARTHUR HOLM

# DynamicVision

Motorized wall mount for videoconference cameras

AHDV04 / AHDV05

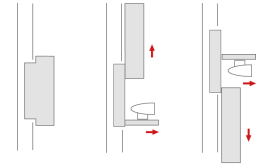

## Highlights

- Motorized wall mount for videoconference cameras
- AHDV04: Upwards moving cover
- AHDV05: Downwards moving cover
- Compatible with the most popular videoconference cameras
- Cover prepared for veneering
- RS-422 and Infrared controllable
- Easy to install

## General

DynamicVision provides the ideal solution to conceal video conference cameras and controls, improving the interior design of the conference room with its easily adaptable front enclosure that can be covered with various materials. The camera is activated via RS-422 or infrared.

When not required, it's neatly stored away, both protecting the camera and securing the work environment. The front enclosure moves vertically to display the camera while moving the camera forward simultaneously. DynamicVision is the perfect solution for systems integrators, architects, interior designers and space planners. The camera can be neatly stored away when not in use.

ARTHUR HOLM

Albiral Display Solutions SL · Fàtima, 25 Sant Hipòlit de Voltregà 08512 Barcelona, Spain · +34 938 502 376 · marketing@arthurholm.com · www.arthurholm.com

Arthur Holm is a registered brand of Albiral Display Solutions SL. Specifications subject to change without previous notice.

Technology serving Design

## Technical Specifications

Movements	
Control Up/Down	AHnet (RS-422)
	IR remote control
	AHLink
Electrical	
External power supply	100-240Vac, 50/60Hz, 12Vdc
Power consumption	25W

## Certifications

- CE
- FCC

## Warranty

- 2 years general warranty

## AHDV04: Consultants, architects and engineer's specifications

The motorized holder and cover up for videoconference cameras shall have tray support that slides in and out and the cover shall move vertically upwards. The cover shall be made of aluminum and shall be prepared for veneering. The cover shall allow a maximum veneer load of 2.5kg/ 5.5lb. The system shall be controlled via infrared and AHnet (RS-422).

## Models

- AHDV04:

Motorized camera wall mount enclosure for videoconference cameras. Upwards moving cover.

Controls: AHLink, AHnet (RS-422) and Infrared remote control.

- AHDV05:

Motorized camera wall mount enclosure for videoconference cameras. Downwards moving cover.

Controls: AHLink, AHnet (RS-422) and Infrared remote control.

## AHDV05: Consultants, architects and engineer's specifications

The motorized holder and cover up for videoconference cameras shall have tray support that slides in and out and the cover shall move vertically downwards. The cover shall be made of aluminum and shall be prepared for veneering. The cover shall allow a maximum veneer load of 2.5kg/ 5.5lb. The system shall be controlled via infrared and AHnet (RS-422).

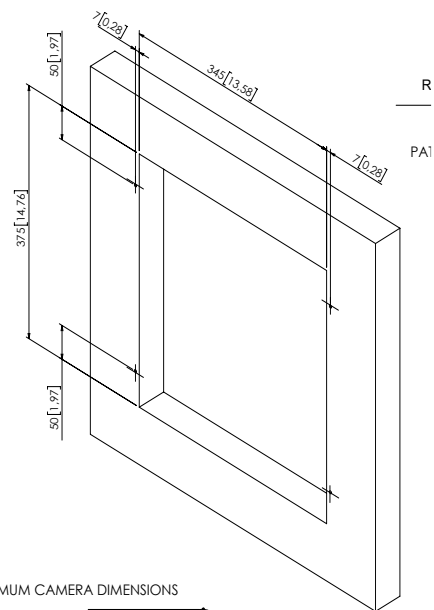
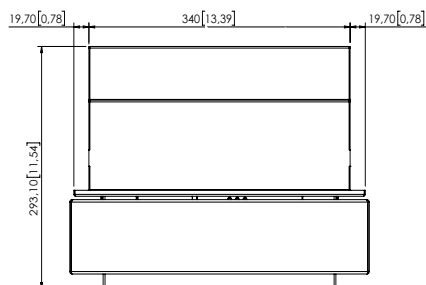
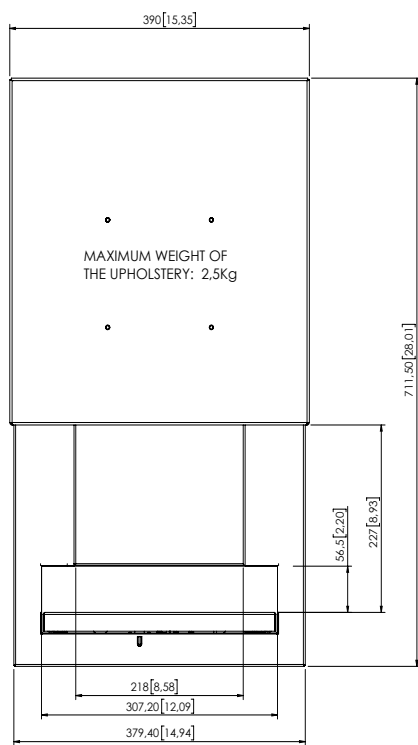
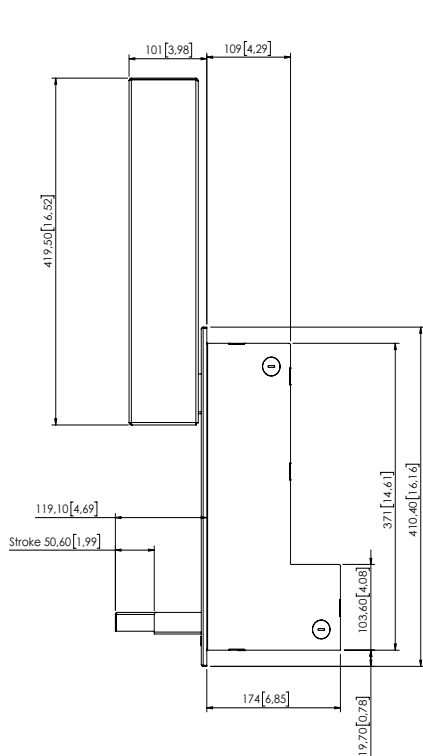

MAXIMUM CAMERA DIMENSIONS

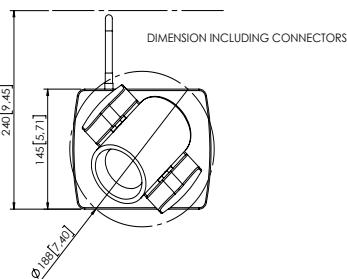
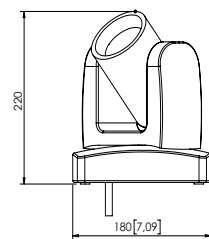

ARTHUR HOLM

Albiral Display Solutions SL · Fàtima, 25 Sant Hipòlit de Voltregà 08512 Barcelona, Spain · +34 938 502 376 · marketing@arthurholm.com · www.arthurholm.com  
Arthur Holm is a registered brand of Albiral Display Solutions SL. Specifications subject to change without previous notice.

Technology serving Design

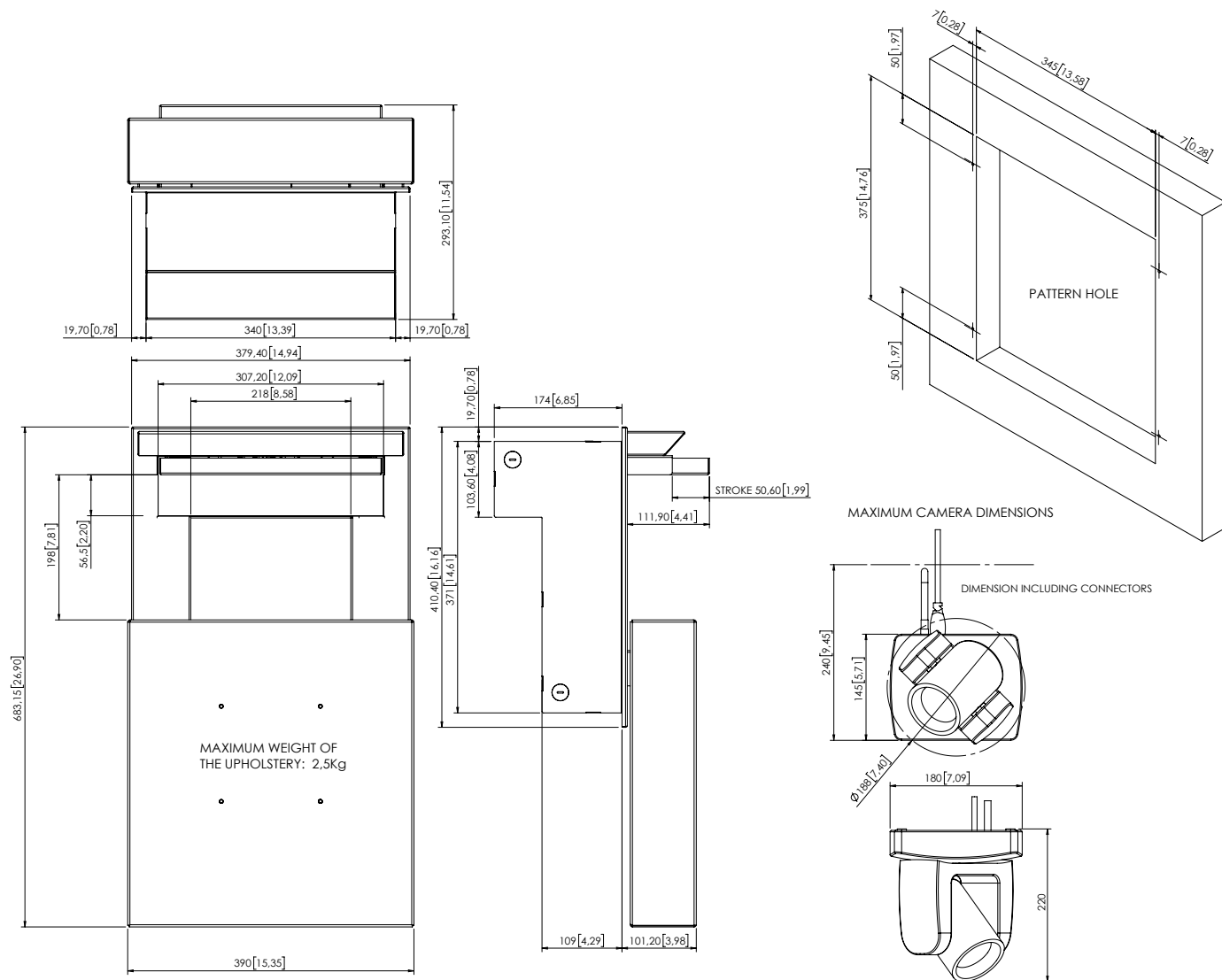

ARTHUR HOLM

Albiral Display Solutions SL · Fàtima, 25 Sant Hipòlit de Voltregà 08512 Barcelona, Spain · +34 938 502 376 · marketing@arthurholm.com · www.arthurholm.com  
 Arthur Holm is a registered brand of Albiral Display Solutions SL. Specifications subject to change without previous notice.

Technology serving Design