

Dynamic3Reverse

HDCP compliant aluminum foldable and rotatable motorized monitor

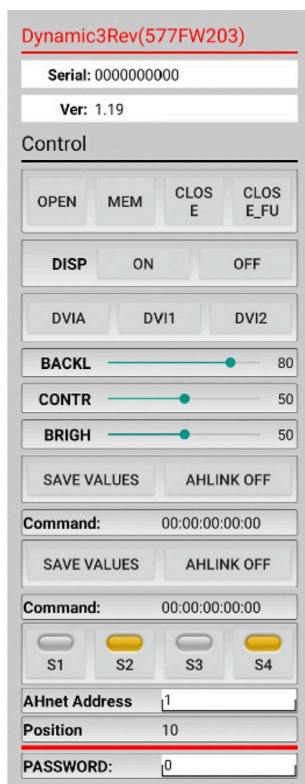

AHlink : the App for setup, control and diagnose



Highlights

- Entirely built of aluminum
- Opens, folds down and rotates 180°
- Adjustable and memorizable tilt angle from 0 to 90°
- 2 DVI I/HDCP compliant
- Energy saving design, low consumption video controller
- Front double sided anti-reflective 2 sides coating 3 mm black edged glass
- Energy saving design, low consumption video controller
- Low profile monitor enclosure
- Serial control and remote diagnosis
- Individual monitor addressing
- ISD: Interactive Setup Display for adjustments and service
- AHlink: Wireless connectivity for setup, adjustments and service
- AH-AMMC: Auto Mechanical Movement Calibration

General

Arthur Holm Dynamic3Reverse is a motorized foldable and rotatable monitor that provides horizontal and vertical adjustable working positions. Its tilt angle can be adjusted at any point from flush on the desk up to 90°. It rotates to be folded with the screen facing down and the rotation axis is located in the area that is closer to the user.

We have selected the best possible aluminum finishing specifications in the world, providing the maximum technical and visual performance and the screen is protected with an anti-reflective 2 side coating 3 mm black edged glass. Dynamic3Reverse is available in 18.5", with 2 DVI-HDCP

compliant inputs and equipped with an interactive setup display (ISD) allowing the control, setup and diagnose of the monitors. The monitor provides RS-422 I/O allowing the remote control of movements, speeds, safety settings, brightness, contrast and backlight. The monitor is equipped with an auto mechanical calibration movement system. The use of the Arthur Holm's ERT will enable the address configuration of all the monitors installed in a table by simply pressing a button. The AHlink Android and iOs app allows getting the serial number without accessing the interior of the table and allows access to the setup and control menu.

Technical Specifications

Display

Size	FULL HD 18.5" TFT Active Matrix
Resolution	1920 (h) x 1080 (v)
Brightness	400 cd/m ²
Contrast ratio	1500:1
Pixel	0.213 (h) x 0.213 (v) mm
Viewing angle	85°/85° (u/d) / 85°/85° (l/r)
Viewing area	408.96 (h) x 230.04 (v) mm
LED backlight lifespan	50,000 hrs
Response time	Tr + Tf = 35 ms
Temperature (operating/storage)	Operating 0°C – +40°C Storage -20°C – +60°C

Materials

Monitor housing	Anodized Aluminum
Glass	AR 2 side with an anti-reflective coating on the glass surface. Thickness: 3.0 ± 0.3 mm
Cover plate	Anonized aluminum

Connectivity

Input signal	DVI-I (1 input) – HDCP Compliant DVI-D (1 input) – HDCP Compliant
RJ45 CAT6 (with loop)	Addressable RS422 monitor control by AHnet protocol
GPI (SubD9)	Movements Control
USB	For service

Control

RJ45, RS-422 (I/O)
Addressing
Termination switch
GPI
IR Remote control (monitor adjustments): 1 / 5

Movement's Control

User interface on monitor	(Up/Down)
Remote	RS-422 I/O/GPI

Electrical

Low voltage (external power supply)	100-240V _{AC} , 50/60Hz, 12V _{DC}
Power consumption	55W

Mechanical

Dimensions:	
Upper cover plate	542 x 434.5 x 4.1 mm [21.33" x 17.1" x 0.16"]
Housing below the table	520 x 413.70 x 102.5 mm [20.47" x 16.28" x 4.03"]
Weight	18 Kg / 39.6 Lbs
Shipping Dimensions:	
Weight	19 Kg / 41.8 Lbs
Shipping Box	582 x 506 x 212 mm [22.9" x 19.92" x 8.3"]

ARTHUR HOLM

Albiral Display Solutions SL · Fàtima, 25 Sant Hipòlit de Voltregà 08512 Barcelona, Spain · +34 938 502 376 · marketing@arthurholm.com · www.arthurholm.com
Arthur Holm is a registered brand of Albiral Display Solutions SL. Specifications subject to change without previous notice.

Technology serving Design

Options

- Projected capacitive multi-touch screen
- Built-in DynamicTalk
- Integrated USB camera
- Integrated connectors on cover plate
- Retractable HDMI cable
- DynamicLoop
- DynamicShare

Finishes

- Laser engraved logo
- Black anodized
- Gold
- Bronze
- Painted

Certifications

- CE
- FCC
- IECEE
- CB

Warranty

- 2 years general warranty

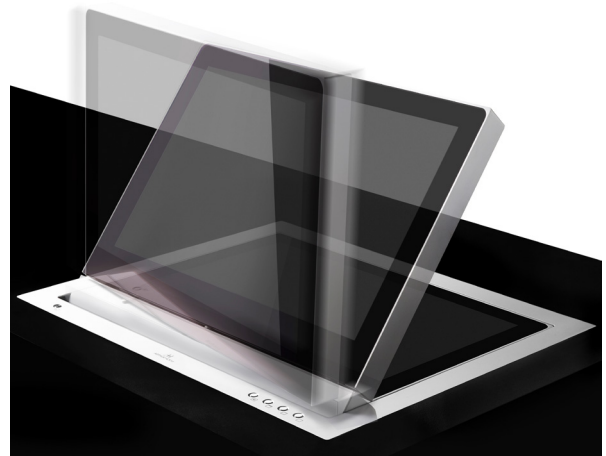

ARTHUR HOLM

Albiral Display Solutions SL · Fàtima, 25 Sant Hipòlit de Voltregà 08512 Barcelona, Spain · +34 938 502 376 · marketing@arthurholm.com · www.arthurholm.com
Arthur Holm is a registered brand of Albiral Display Solutions SL. Specifications subject to change without previous notice.

Technology serving Design

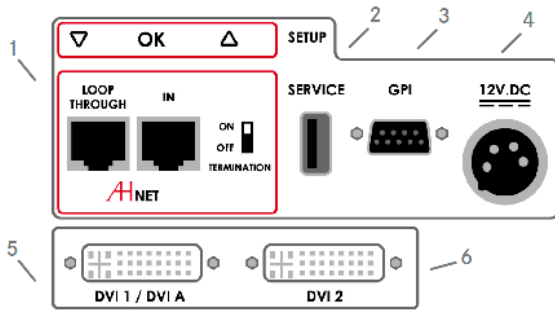

Connectivity

- 1- AHnet control interface
- 2- USB for Service
- 3- GPI control
- 4- Power input
- 5- DVI 1 / DVI A video input
- 6- DVI 2 video input

Interactive Setup Display

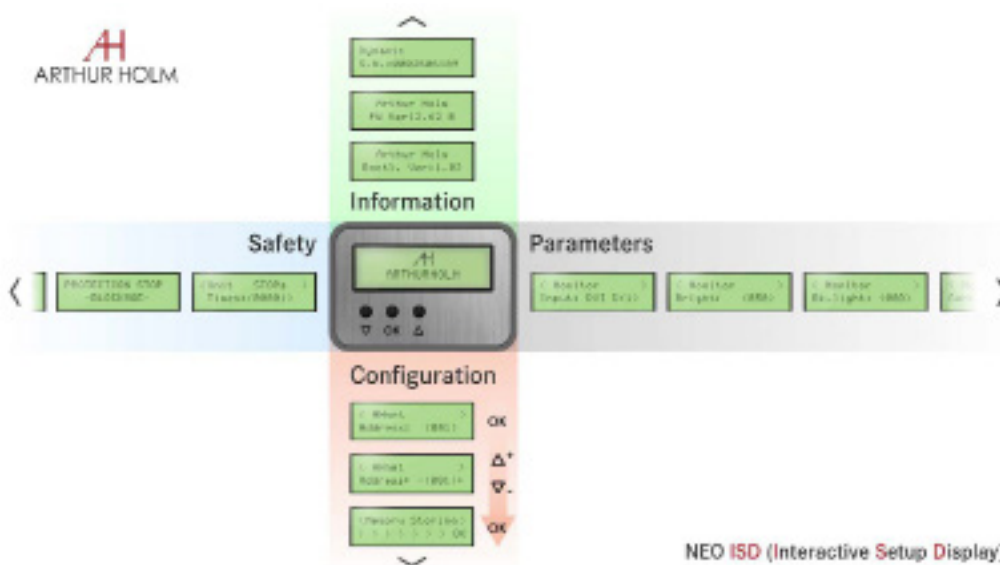

Consultants, architects and engineers specifications

Motorized foldable and rotatable 18,5" Full HD professional monitor. The monitor housing shall be made of milled anodized aluminum and the screen shall be protected with an anti-reflective 2 side coating black edged 3 mm. glass. The monitor shall have a brightness of 400 cd/m2, a contrast ratio of 1500:1 and backlight lifespan of 50,000 hours. The monitor shall provide horizontal flush on desk and vertical up to 90 ° working positions. The position shall be stopped at any point from 0 to 90 ° and shall provide a memory system. The monitor shall rotate 180 ° to be closed with the screen facing down. The monitor shall provide 2 DVI HDCP inputs by a licensed HDCP monitor manufacturer.

The monitor shall provide and addressable RS-422 and an easy to read interactive setup display (ISD) to access the safety parameters, the setup of the speeds and the control of the brightness, contrast and backlight. The monitor shall be able to run an auto-adjustment program to reset the factory security ratio between its factory movement speed and its protection parameters adapting the unit to the way it has been installed. The monitor shall provide a USB port for firmware upgrades. The monitor shall be controlled by a wireless Android and iOS app providing information about the monitor's serial number, and providing access to the control and to the setup menu.

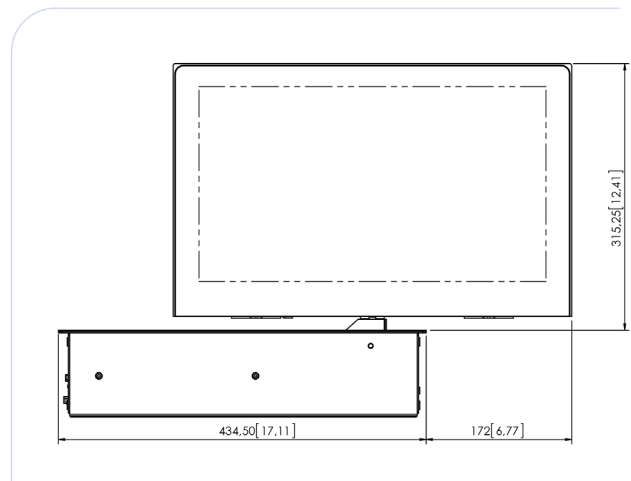
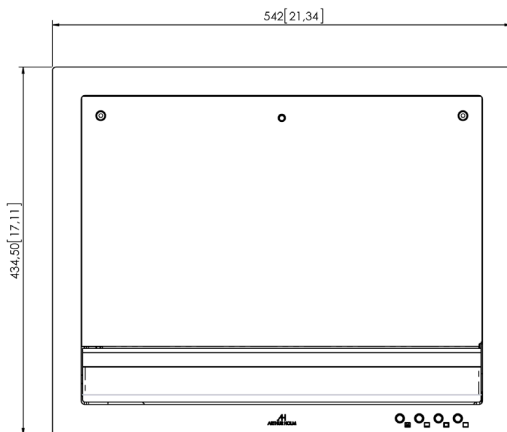
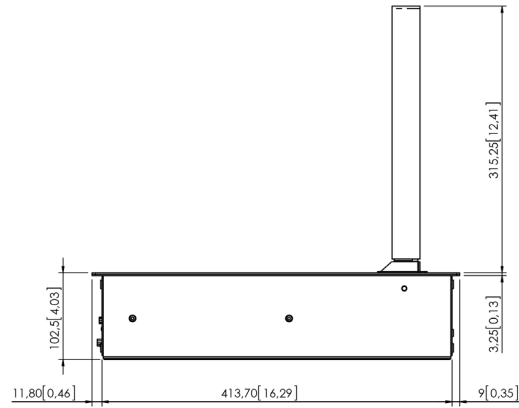
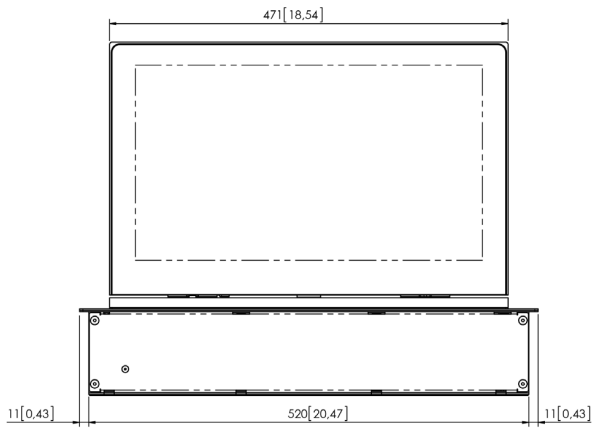

ARTHUR HOLM

Albiral Display Solutions SL · Fàtima, 25 Sant Hipòlit de Voltregà 08512 Barcelona, Spain · +34 938 502 376 · marketing@arthurholm.com · www.arthurholm.com
 Arthur Holm is a registered brand of Albiral Display Solutions SL. Specifications subject to change without previous notice.

Technology serving Design