

## Dynamic3Talk

HDCP compliant aluminium foldable monitor with integrated independent microphone lift system



This picture corresponds to a customised version of Dynamic3Talk

### FEATURES

- Aluminium foldable monitor with an independent microphone lift
- Entirely built of aluminium
- Opens and folds down
- Synchronised tray lift movement
- 360 ° LED lighting to indicate microphone status
- Interactive Setup Display (ISD)
- Maintenance free
- HDCP compliant
- Energy saving design, low consumption video controller
- Serial control and remote diagnosis
- Wireless connectivity for setup and control
- Auto Mechanical Movement Calibration (AH-AMMC)

### GENERAL

Arthur Holm Dynamic3Talk is a motorised foldable product range that includes an independent lift for gooseneck microphones. The aluminium monitor rises and folds down. The screen's lifting system automatically activates the elevation of a tray where keyboard and mouse can be placed. The aluminium cover plate has been enlarged to include an independent lift system for microphone with a rounded microphone coverlid that not only makes the microphone disappear within the desk surface, but it also provides a pleasant light to indicate its status. Thanks to its protective and patented lighting ring, the microphones can be safely stored and protected making meeting and conference spaces more flexible and versatile. This system provides two different working modes: PA and Conference. When in PA mode, a push button placed on the stainless steel cover plate allows to activate or de-activate the microphone and the LED ring will indicate the status by changing colour from red to green. The system will automatically silence the microphone when retracting.

When in conference mode, the microphone will be always active and both, the light ring and the access to the push button on the cover plate, will be available via GPI and GPO for remote control. The microphone lift can be adjusted to the exact length of the microphone via AHnet and AHlink. The AHlink is an excellent tool to diagnose, verify and configure Dynamic3 and DynamicTalk. The monitor is equipped with an Interactive Setup Display (ISD) allowing the control, setup and diagnose of the monitors. Monitors provide RS-422 I/O allowing the remote control of movements, speeds, safety settings, brightness, contrast and backlight. The monitors are equipped with an Auto Mechanical Calibration Movement System (AH-AMMC). The use of the Arthur Holm's ERT will enable the address configuration of all the monitors installed in a table by simply pressing a button. The app AHlink Android and iOS allows getting the unit's serial number without the need to have access to the unit from below the table.

### ARTHUR HOLM

Albiral Display Solutions SL · Fàtima, 25 Sant Hipòlit de Voltregà 08512 Barcelona, Spain · +34 938 502 376 · marketing@arthurholm.com · www.arthurholm.com  
Arthur Holm is a registered brand of Albiral Display Solutions SL. Specifications subject to change without previous notice.

Technology serving Design

**Display**

Size	FULL HD 18.5" TFT Active Matrix
Resolution	1920 (h) x 1080 (v)
Brightness	400 cd/m2
Contrast ratio	1500:1
Pixel	0.213 (h) x 0.213 (v) mm
Viewing angle	85° / 85° (u/d) / 85° / 85° (l/r)
Viewing area	408.96 (h) x 230.04 (v) mm
LED backlight lifespan	50,000 hrs
Response time	Tr +Tf =35ms
Temperature <i>(operating/storage)</i>	Operating 0°C – +40°C Storage -20°C – +60°C

**Materials**

Monitor housing	Anodised Aluminium
Glass	AR 2 side with an anti-reflective coating on the glass surface. Thickness: 3.0 ± 0.3 mm
Cover plate	Anonised aluminium

**Connectivity**

Input signal	DVI-I (1 input) – HDCP Compliant DVI-D (1 input) – HDCP Compliant
RJ45 CAT5 (with loop)	Addressable RS422 monitor control by AHnet protocol
GPI (SubD9)	Movements Control
USB	For service

**OPTIONS**

- DynamicLoop
- DynamicShare
- Projected capacitive multi-touch screen
- Integrated connectors on cover plate
- Retractable HDMI cable
- Laser engraved logotype on cover plate
- Keyboard and mouse
- Priority button
- Anodised in black
- Gold finish
- Bronze finish
- Painted

**Control**

RJ45, RS-422 (I/O)
Addressing
Termination switch
GPI
IR Remote control (monitor adjustments): 1 / 5

**DynamicTalk Control**

Up/Down Control	Button on upper cover plate GPI contact closer RS-422 (RJ45 CAT 5)
Microphone control	Button on upper cover plate
Customised function	
GPI/O	LEDs control, up/down and switch

**Electrical**

Two external power supply <i>(Low voltage)</i>	100-240Vac, 47/63Hz, 12Vdc
Display consumption	55W
DTalk consumption	10W

**Mechanical**

Dimensions:	
Upper cover plate	542 x 435 x 3.25 mm [21.33" x 17.12" x 0.98"]
Housing below the table	527 x 413.70 x 102.45 mm [20.74" x 16.28" x 4.03"]
Weight	22.5 Kg / 49.6 Lbs
Shipping Dimensions:	
Weight	23.5 Kg / 51.8 Lbs
Shipping Box	672 x 717 x 207 mm [26.45" x 28.22" x 8.14"]

**BENEFITS**

- Flexibility and versatility
- No loss of work space
- Low profile monitor enclosure
- Keyboard and mouse storage space

**CERTIFICATIONS**

- CE
- FCC
- IECEE

**WARRANTY**

- 2 years limited warranty

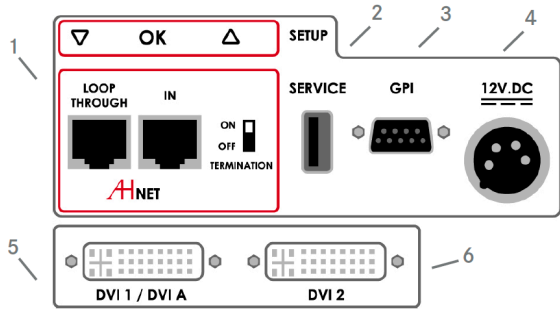

CONNECTIVITY

- 1- AHnet control interface
- 2- USB for Service
- 3- GPI control
- 4- Power input
- 5- DVI 1 / DVI A video input
- 6- DVI 2 video input

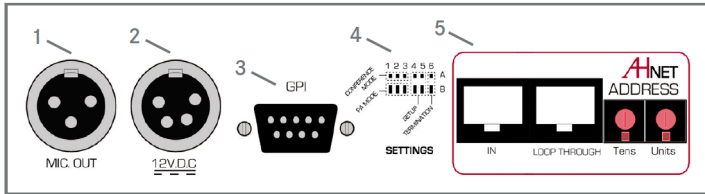

DYNAMIC TALK CONNECTIVITY

- 1- Microphone output
- 2- Power input
- 3- GPI control
- 4- DynamicTalk configuration settings
- 5- AHnet control interface

INTERACTIVE SETUP DISPLAY (ISD)

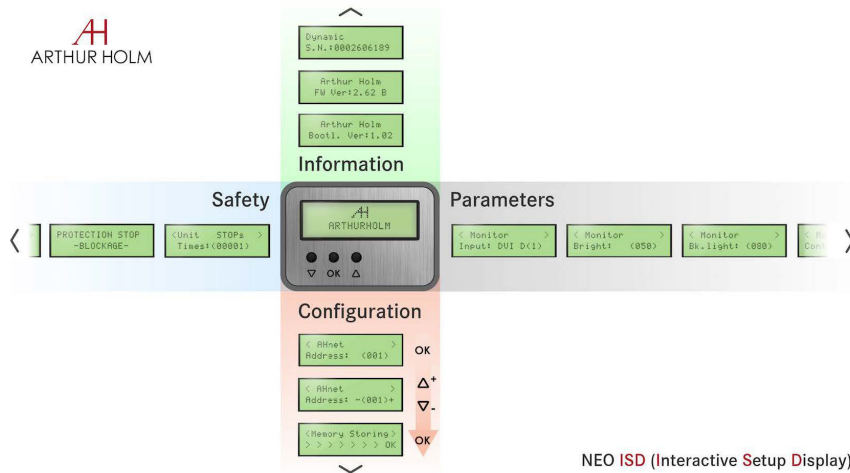

NEO ISD (Interactive Setup Display)

CONSULTANTS, ARCHITECTS AND ENGINEERS SPECIFICATIONS

Motorised foldable 18,5" professional monitor. The monitor housing shall be made of milled anodised aluminium and the screen shall be protected with anti-reflective 2 side coating black edged 3 mm glass. The monitor shall have a brightness of 400 cd/m2, a contrast ratio of 1500:1 and a backlight lifespan of 50,000 hours. The monitor's opening mechanism shall activate automatically the rising of a synchronised aluminium tray covering the entire opening surface. The monitor shall be capable to be folded with the screen facing down. The monitor shall provide 2 DVI HDCP inputs by a licensed HDCP monitor manufacturer. The monitor shall provide an addressable RS-422 and an easy to read interactive setup display (ISD) to access the safety parameters, the setup of the speeds and the control of the brightness, contrast and backlight and remote setup support and diagnostic. The monitor shall provide a dual safety system that detects obstructions causing the unit to stop through a floating security sensor. The monitor shall be able to run an auto-adjustment program to reset the factory security ratio between its factory movement speed and its protection parameters adapting the unit to the way it has been installed. The monitor shall provide a USB port for firmware upgrades. The monitor shall be controlled by a wireless Android and iOS app providing

information about the monitor's serial number, and providing access to the control and to the setup menu. The system shall include an independent lift system for 3 pin XLR gooseneck microphones in the cover plate. This cover plate shall provide a rounded microphone coverlid and 3 operation buttons; open/close, mute/unmute the microphone and free GPO button. The lift system includes a translucent plastic rounded ring to centre the microphone during its rise and retract movement from a position hidden below the cover to a top position projected through the cover, avoiding the microphone from touching the cover plate, damaging or blocking when retracting. This ring shall provide a programmable green and red LED to indicate the microphone status and shall be visible 360°. The system shall provide a safety system that detects obstructions and causes the unit to stop with an audio indication. The unit shall provide and auto-calibration mode to reset mechanical speeds and safety adjustments. The unit shall be compatible with a wireless app that allows the exact adjustment of the microphone length, facilitates the unit's serial number, allows the activation and de-activation of the RS-422 termination and allows to change the working mode from PA to Conference.

