

DB3

HDCP compliant aluminum motorized monitor

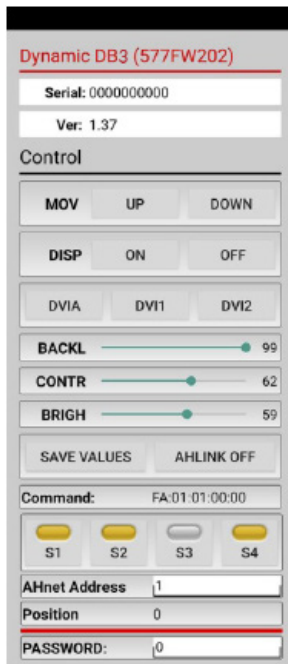
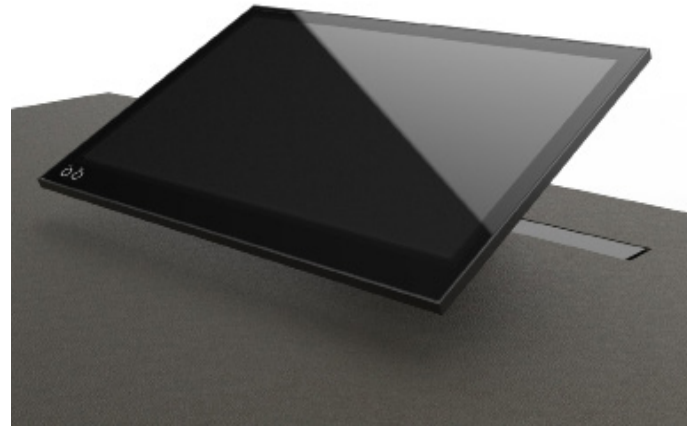

Highlights

- Vertical motorized monitor with inclination of 20-90°
- Adjustable tilt angle with memory
- 10mm edge and total thickness of 20 mm
- Automated hatch in black aluminum or for table surface matching
- Milled black anodized aluminum housing
- Dual side anti-reflective 2 mm. black-edged glass
- Energy saving design, low consumption video controller
- HDCP compliant DVI inputs
- RS422/RS485 I/O
- ISD: Interactive Setup Display for adjustments and setup
- AHlink: Wireless connectivity for setup, adjustments, and control
- AH-AMMC: Auto mechanical Movement Calibration

AHlink : the App for setup, control and diagnose



General

Professional 21.5” motorized monitor with a minimal impact on the table’s design when retracted and an astonishing impact on the table when ejected. The automated hatch has a black anodized aluminum finish. The unique design of the automated hatch allows it to be matched to the table surface by adding the same material as the tabletop on top of it, providing a streamlined finish to the furniture. The user can adjust the screen position for comfort and visibility, with full view of the other participants around the table. The screen inclines smoothly towards the user, who can stop the movement and lock the position at the desired angle, from 90 to 20°. A memory function will allow to store and recall the desired position. The elegance of the design is timeless, and the movements are harmonious and silent. The materials selected for crafting this innovative, retractable monitor are sustainable, comprising aluminum and glass. The 21.5” LCD professional display panel ensures a long lifespan. The in-house designed electronics prioritize energy efficiency, while the AHlink app

facilitates a comfortable and intuitive adjustment during integration and throughout the monitor’s lifespan.

The retractable monitor is equipped with 2 x DVI HDCP compliant inputs and an Interactive Setup Display for setup, control and diagnose. The monitor provides RS422/485 loop through (I/O) allowing the remote control of the input selection, movements, speeds, safety settings, brightness, contrast and backlight adjustments. It can also be adjusted and controlled via the wireless application: AHlink.

The AHlink app is available for Android and iOS and gives access to the setup menu and information about the monitor, such as serial number and firmware version, without access to the monitor in the table.

The Auto Mechanical Movement Calibration will automatically adjust the speed and the safety protection parameters.

The use of the ERT-30 and the ERT-60 enables an automatic individual address configuration of all the monitors in a table.

Technical Specifications

Display

| | |
|---------------------------------|---|
| Size | FULL HD 21.5" TFT Active Matrix, widescreen format. LED backlight |
| Resolution | 1920 (h) x 1080 (v) |
| Brightness | 350 cd/m2 |
| Contrast ratio | 1000:1 |
| Pixel | 0.24975 (h) x 0.24975 (v) mm |
| Viewing angle | 89°/89°(l/r) 89°/89°(u/d) |
| Viewing area | 476.064 (h) x 267.786 (v) mm |
| LED backlight lifespan | 50,000 hrs |
| Response time | Tr 12ms, Tf 10ms |
| Temperature (operating/storage) | Operating 0°C ~ +40°C Storage -20°C ~ +60°C |

Materials

| | |
|-----------------|---|
| Monitor housing | Solid mechanized aluminum housing with black anodized finish. Front black serigraphed glass |
|-----------------|---|

Connectivity

| | |
|-----------------|--|
| Input signal | DVI-I (1 input) – HDCP compliant DVI-D (1 input) – HDCP compliant |
| RJ45 CAT6 (I/O) | Addressable RS-422/RS-485 control by AHnet protocol |
| GPI (SubD9) | Up/Down control (opto isolated) |
| USB | For service (firmware upgrades) |

Control

| |
|---|
| RJ45, RS-422/RS-485 (I/O), AHnet protocol |
| AHlink |
| Addressing |
| Termination switch |
| GPI |
| IR Remote control (monitor adjustments) |

Movement's Control

| | |
|---------------------------|-----------------------------------|
| User interface on monitor | (Up/Down) Capacitive touch sensor |
| Remote | RS-422/RS-485 (I/O), GPI |
| AHlink | |

Electrical

| | |
|-----------------------|-----------------------------|
| External power supply | 100-240 Vac, 47/63Hz, 12Vdc |
| Power consumption | 50W |

Accessories

| | |
|-----------------|-------------------------|
| ERT-30 / ERT-60 | Ethernet Interface Unit |
|-----------------|-------------------------|

Mechanical

| | |
|-------------------------|--|
| Monitor Dimensions: | |
| Screen | 518 x 342 x 40 mm [20.39" x 13.45x 1.57"] |
| Top frame | 534 x 47 mm [21.02" x 1.85"] |
| Housing below the table | 602 x 601 x 145.50 mm [23.70" x 23.66" x 5.75"] |
| Weight | 20.5 Kg / 45.19 Lbs |
| Shipping Dimensions: | |
| Weight | 21.5 Kg / 47.39 Lbs |
| Shipping Box | 735 x 725 x 265 mm [28.94" x 28.54" x 10.43"] |

ARTHUR HOLM

Albiral Display Solutions SL · Fàtima, 25 · 08512 Sant Hipòlit de Voltregà · Barcelona, Spain · +34 938 502 376 · marketing@arthurholm.com · www.arthurholm.com
Arthur Holm is a registered brand of Albiral Display Solutions SL. Specifications subject to change without previous notice.

Make Your Meetings Count!

Options and accessories

- 2/ HDMI inputs
- DynamicTalk
- DynamicLoop
- DynamicShare
- Projected capacitive multi-touch screen
- Integrated USBC retractable cable
- Motorized USB camera
- Automated hatch ready for veneering with capacitive sensor

Warranty

- 2 years general warranty

ARTHUR HOLM

Albiral Display Solutions SL · Fàtima, 25 · Sant Hipòlit de Voltregà - Barcelona, Spain · +34 938 502 376 · marketing@arthurholm.com · www.arthurholm.com
Arthur Holm is a registered brand of Albiral Display Solutions SL. Specifications subject to change without previous notice.

Make Your Meetings Count!

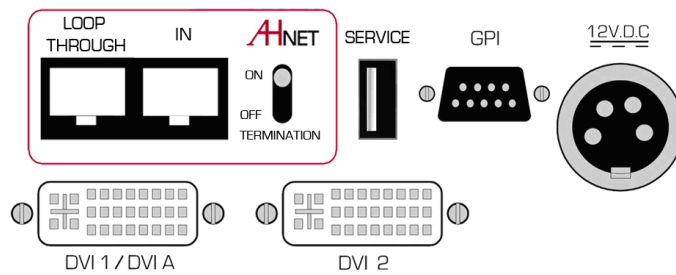

Interactive Setup Display (ISD)

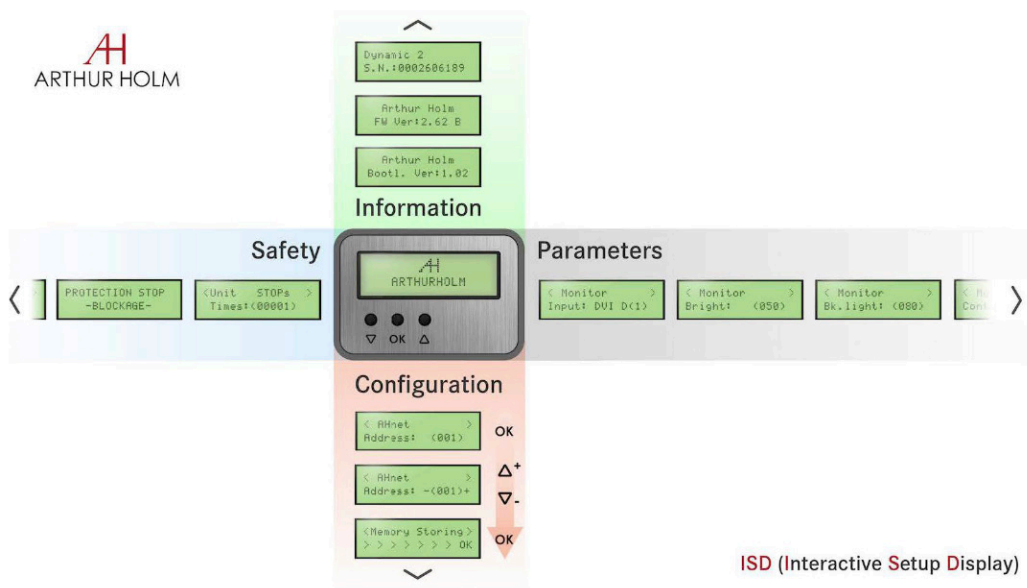

ISD (Interactive Setup Display)

Consultants, architects and engineers specifications

Vertically motorized 21.5" Full HD professional monitor with an inclination from 90 to 20 degrees on the table surface. The monitor housing shall be made of milled anodized aluminium with a maximum thickness of 20mm and the screen shall be protected with an anti-reflecting 2 side coating 2mm glass. The automated hatch shall slide down inside the mechanism and shall close the table cut off flush on the table. A capacitive button shall be placed on the automated hatch to activate the monitor's movement. The movements of the monitor shall be controlled by 2 buttons located on the monitor's front glass; the user shall memorize the monitor's position, by pressing both movement control buttons simultaneously.

Optionally, an Input Source Selection shall be located on the monitor's front glass to switch between the different signal inputs. The monitor shall have a brightness of 350 cd/m2, a contrast ratio of 1000:1 and a backlight lifespan of 50,000 hours. The monitor shall provide 2 DVI HDCP inputs by a licensed HDCP manufacturer. The monitor shall provide a USB port for firmware upgrades. The monitor shall provide RS-422/RS-485 Full Duplex for the AHnet protocol and an Easy-to-Read Interactive Setup Display (ISD) for the setup, diagnose and control, and shall be compatible with ERT-30 and ERT 60. The monitor shall be compatible with the AHlink wireless Android and iOS App for the setup, diagnosis and control.

General Dimensions

AH22DB3

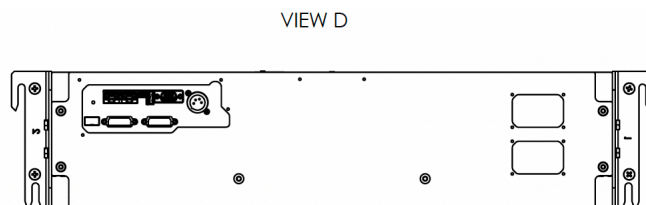
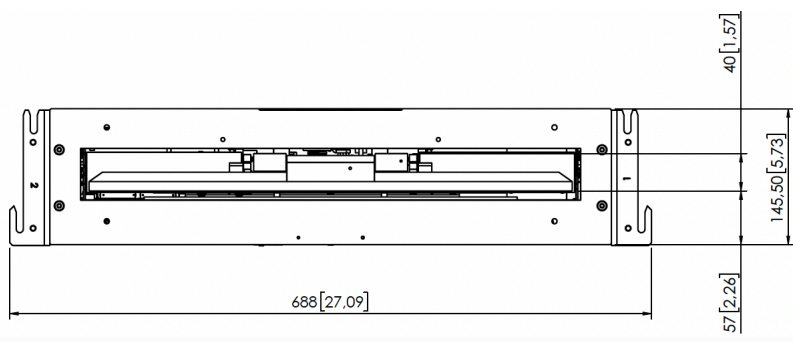
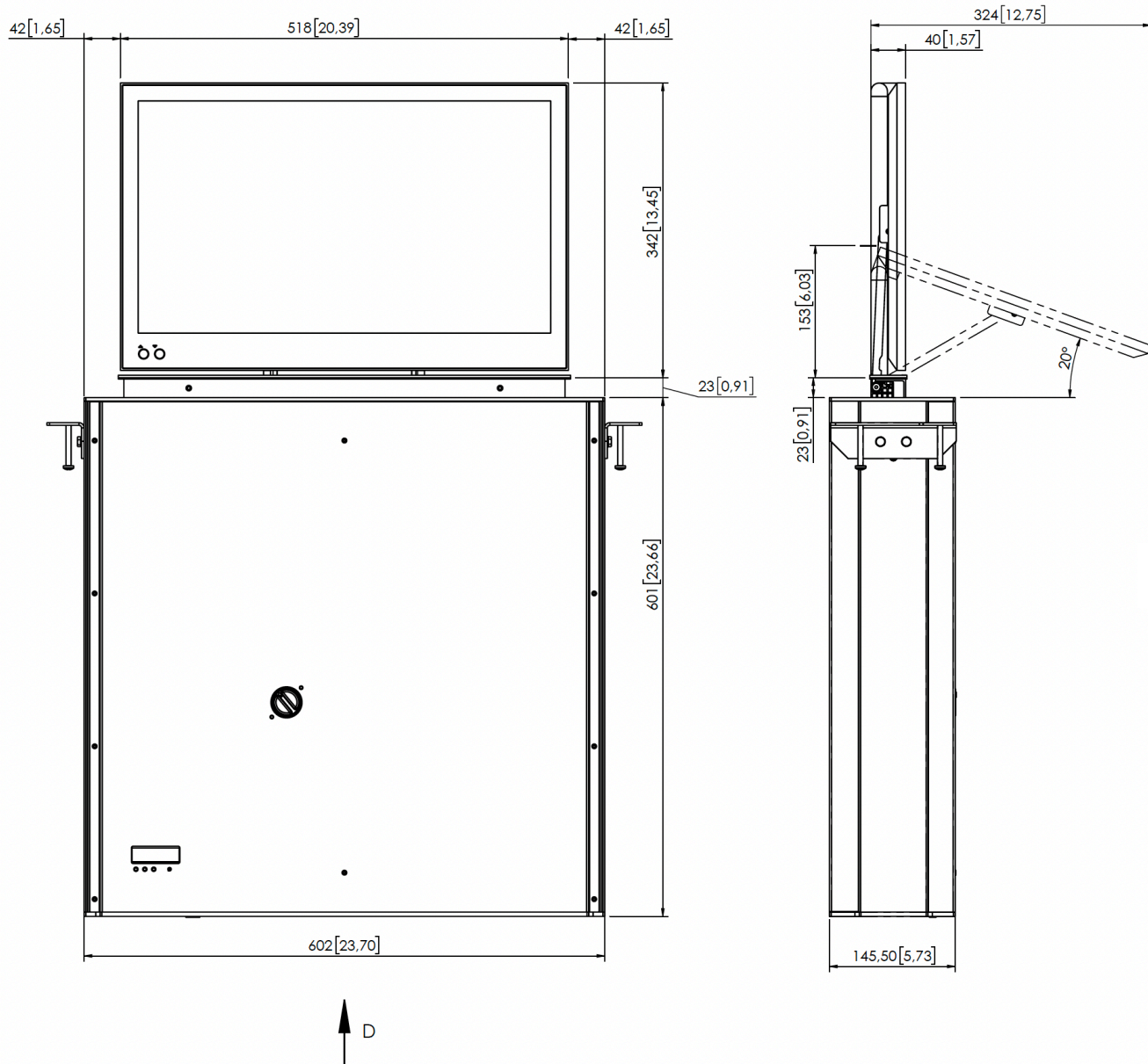

ARTHUR HOLM

Albiral Display Solutions SL · Fàtima, 25 · 08512 Sant Hipòlit de Voltregà · Barcelona, Spain · +34 938 502 376 · marketing@arthurholm.com · www.arthurholm.com
 Arthur Holm is a registered brand of Albiral Display Solutions SL. Specifications subject to change without previous notice.

Make Your Meetings Count!